

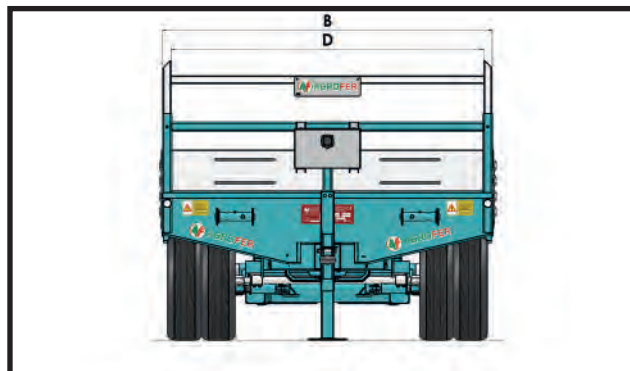

# PIANALE P.T.M.

Con omologazione stradale 8000 - 10.000 - 12.000 KG

- Telaio in tubolare sezionato
- Ribaltamento idraulico con pistone a doppio effetto
- Pedana posteriore per carico macchine intera ma divisa
- Pianale in ferro lamiera bugnata 30 decimi
- Impianto di segnalazione stradale (fanali)
- Piedino di stazionamento anteriore idraulico
- Sospensioni con sistema tandem a bilanciere cantilever con balestra
- Frenatura pneumatica su 4 ruote 300x60
- Ochione F2
- Paratia anteriore telescopica
- N° 2 verricelli tendi fune anteriori
- Ganci laterali per funi
- Trattore n°1 coppia di prese idrauliche a doppio effetto
- Ruote usate rigenerate

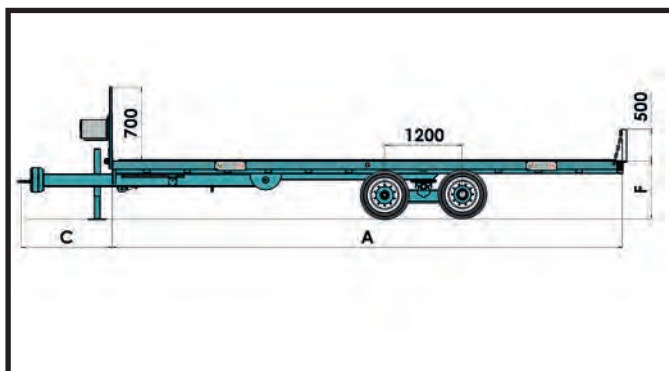

## PIANALE P.T.M. Con assale posteriore fisso

MOD.	A mm	B mm	C mm	D mm	F mm		 Kg.		CERTIFICATO OMOLOGAZIONE STRADALE ITALIANA 8000-10000-12000 Kg
P.T.M. 50x22	5000	2250	1500	2190	850	215/75 R17.5	2220		
P.T.M. 61x22	6100	2250	1500	2190	850	215/75 R17.5	2960		
P.T.M. 61x24	6100	2450	1500	2390	850	215/75 R17.5	2960		
P.T.M. HI 76x24	7600	2450	1500	2390	850	215/75 R17.5	3150		

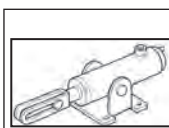

**A RICHIESTA SISTEMA FRENANTE PER 8000-10000-12000 kg**



IDRAULICO A PEDALE

# PIANALE P.T.M. AS

## CON ASSALE POSTERIORE STERZANTE CON BLOCCAGGIO IDRAULICO

MOD.	A mm	B mm	C mm	D mm	F mm		 Kg.		CERTIFICATO OMOLOGAZIONE STRADALE ITALIANA 8000-10000- 12000 Kg
P.T.M. 50x22 AS	5000	2250	1500	2190	850	215/75 R17.5	2220		
P.T.M. 60x22 AS	6100	2250	1500	2190	850	215/75 R17.5	2960		
P.T.M. 61x24 AS	6100	2450	1500	2390	850	215/75 R17.5	2960		
P.T.M. HI 76x24 AS	7600	2450	1500	2390	850	215/75 R17.5	3150		

**A RICHIESTA SISTEMA FRENANTE PER 8000-10000-12000 Kg**

