

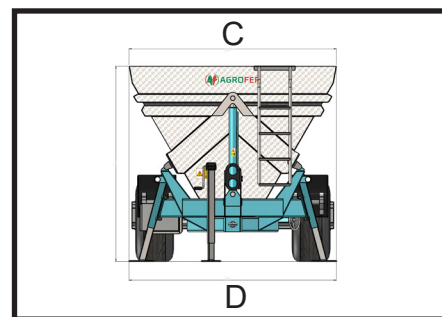

CARRO BL MONOASSE INOX

- Carro con scarico laterale BL Dx Sx
- Telaio in tubolare sezionato
- Ribaltamento bilaterale lato DX+SX con cilindri a doppio effetto funzionamento olio trattore
- Timone fisso con occhione E3
- Assale rigido a 6 fori con freno meccanico
- Piedino anteriore di appoggio manuale
- Kit fanali
- Trattore N1 presa idraulica a doppio effetto OLIO TRATTORE NECESSARIO 30lt
- Vasca a tenuta stagna in acciaio inox con lamiera fiorettata aisi 304

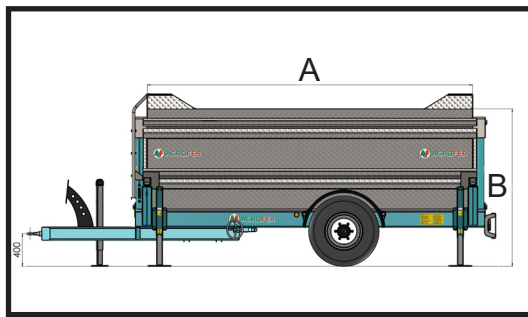
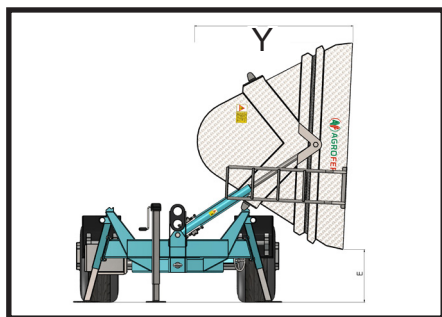
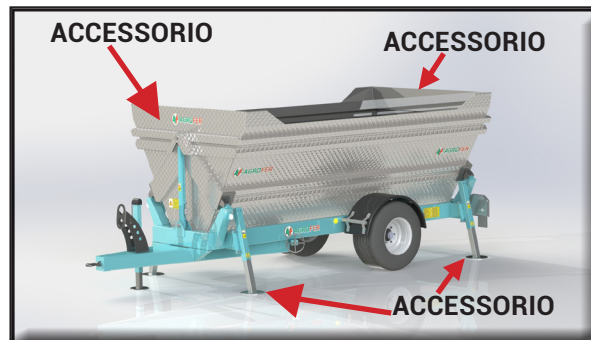

MOD.	A mm	B mm	C mm	D mm	Y mm		 Kg.	 m ³		CERTIFICATO OMOLOGAZIONE ITALIANA 6.000kg
BL30	3000	1800	1800	1800	1200	10.075 15.3	1600	4		
BL40	4000	2200	1800	1800	1200	13/65 - 18	1750	6,5		

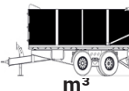
COSTI SISTEMA FRENANTE PER OMOLOGAZIONE STRADALE 6000Kg

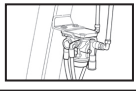
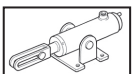
	PNEUMATICO	
	IDRAULICO A PEDALE	